

# HINO 338H SERIES



# 2010

## TRUCK CHASSIS SPECIFICATIONS

(NF8J) SS-NF008

GVW: 15,000 kg (33,000 lbs.)

ENGINE MODEL: J08E-TV (Turbo Intercooled)

All 2010 models require ultra-low sulfur diesel fuel

### DIMENSIONS (On standard specifications)

MODEL		NF8JRSA		NF8JTSA		NF8JVSA	
Wheelbase	A mm(in.)	5,969	(235.0)	6,426	(253.0)	6,883	(271.0)
Overall length	B mm(in.)	9,464	(372.6)	9,921	(390.6)	9,921	(390.6)
Overall width	C mm(in.)	2,485	(97.8)	2,485	(97.8)	2,485	(97.8)
Overall height	D mm(in.)	2,720	(107.1)	2,720	(107.1)	2,720	(107.1)
Cab to axle	E mm(in.)	4,257	(167.6)	4,714	(185.6)	5,171	(203.6)
Rear overhang	F mm(in.)	2,464	(97.0)	2,464	(97.0)	2,007	(79.0)
Frame height at							
Front axle	G mm(in.)	940	(37.0)	940	(37.0)	940	(37.0)
Rear axle	H mm(in.)	1,030	(40.6)	1,030	(40.6)	1,030	(40.6)
Road clearance							
(at front axle)	J mm(in.)	285	(11.2)	285	(11.2)	285	(11.2)
Tread							
Front	K mm(in.)	2,005	(78.9)	2,005	(78.9)	2,005	(78.9)
Rear	L mm(in.)	1,870	(73.6)	1,870	(72.0)	1,870	(72.0)
Turning radius							
Tire	mm(in.)	9,450	(372.0)	10,120	(398.4)	10,780	(424.4)
Swept	mm(in.)	9,980	(392.9)	10,650	(419.3)	11,310	(445.3)

### CHASSIS WEIGHTS (On std. spec., without spare tire & std. tool set)

MT Total weight	kg(lb.)	-	-	4,545	(10,020)	4,660	(10,270)
Front axle	kg(lb.)	-	-	2,915	(6,425)	3,000	(6,610)
Rear axle	kg(lb.)	-	-	1,630	(3,595)	1,660	(3,660)
AT Total weight	kg(lb.)	4,500	(9,920)	4,515	(9,950)	4,635	(10,220)
Front axle	kg(lb.)	2,865	(6,315)	2,885	(6,355)	2,970	(6,550)
Rear axle	kg(lb.)	1,635	(3,605)	1,630	(3,595)	1,665	(3,670)

### POWER LINE & PERFORMANCE

[15,000 kg (33,000 lbs.) GVW & 11.00R22.5-14 tires]

Power line	□ STD.	□ OPT.	□ STD.	□ OPT.
Max. speed km/h	121	124	121	124
Gradeability (tan.θ) %	37.2	36.2	33.5	32.7
Transmission Model	Eaton FS5406A		Allison 2500RDS	
Type	Six-speed direct drive synchromesh 1st-6th		Six-speed automatic	
1st.	9.008		3.512	
2nd.	5.270		1.896	
3rd.	3.220		1.439	
Ratios	4th. 2.040		1.000	
5th.	1.361		0.737	
6th.	1.000		0.640	
Rev.	8.625		5.086	
Rear axle gear ratios	4.110	3.900	5.570	5.290

Option ratio is combined with 295/75R22.5 tire.

### ENGINE

Model	HINO J08E-TV
Type:	Diesel 4-cy., 6-cyl. in-line, water-cooled
Combustion system:	Direct injection type
Max. output: (SAE Gross)	220HP at 2,500 rpm
Max. torque: (SAE Gross)	706 N·m (520 lb.-ft.) at 1,500 rpm
Bore and stroke:	112 x 130 mm (4.41 x 5.12 in.)
Piston displacement	7.680 L (468.8 cu.in.)
Fuel injection system:	Common rail ND
Governor:	Electronically controlled
Intake system:	Turbocharged and intercooled
Air cleaner:	Paper filter type ("DONALDSON")
Pre-Heater:	Glow heater plug type
Fan clutch:	Bimetal thermostat sensor regulates fan speed
Block heater:	1,000 watts/120V immersion type

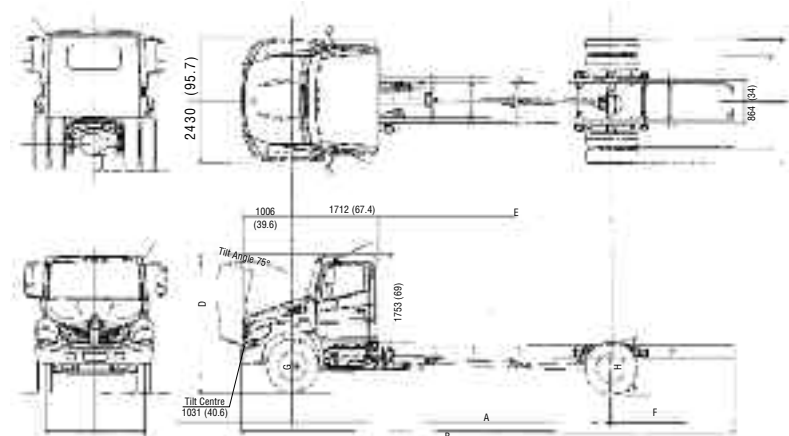

THE QUALITY CHOICE.

www.hinocanada.com

**WEIGHT CAPACITIES**

Front axle	kg(lbs.)	5,455 (12,000)
Rear axle	kg(lbs.)	9,545 (21,000)
Front spring	kg(lbs.)	5,455 (12,000)
Rear spring	kg(lbs.)	9,545 (21,000)

**LIQUID CAPACITIES**

Fuel tank ltr.(gal./US)	196.8 (52), aluminum
Cooling system	23.5 (6.21)
ltr.(gal./US)	: Eaton FS5406A
	23.0 (6.08)
	: ALLISON 2500RDS

**AXLE / SUSPENSION**

Front axle	MFS-12 series reversed Elliot, "I" beam, Oil lubricated front wheel bearings
Front spring	Taper-leaf springs w/ shock absorbers
Rear axle	RS21-145 series Full-floating, single reduction Single-speed by hypoid gears
Rear spring	Semi-elliptic main and auxiliary helper, - leaf spring
Option:	Two air bag suspension with shock absorbers and dump valve

**FRAME**

Ladder type	Straight ] section
Width mm(in.)	863.6 (34)
Tensile strength kg/mm <sup>2</sup> (lb/in) <sup>2</sup>	63.4 (90,143)
Resisting bending moment (one side)	1,188,862 (1,031,900) no reinforcement
	kg•cm (in•lbs.)

**STEERING**

Type	Telescopic and tilt steering column with lock Recirculating ball, with hydraulic booster integral type
------	--

**CLUTCH**

Type	Dry single plate with damper springs EATON-SPICER Solo 1401 series
Facing material	Cerametallic
Facing outside diameter mm (in.)	350 (13.8)
Control	Hydraulic

**WHEELS / TIRES**

Wheels	22.5X8.25, 10-stud disc.
Tires	11R22.5(G)
Brand & Pattern	BS Fr: RIB, Rr: LUG

**BRAKES**

Service brake	Hydraulic system with disc brake for front and rear wheels, with automatic adjustment
Disc diameter	Front;
x pad area (cm <sup>2</sup> )	390.5 x 122.3 x 18.8
x thickness	15.375 x 18.96 x 0.74)
mm(in.)	Rear;
	390.5 x 122.3 x 18.8 (15.375 x 18.96 x 0.74)
Control	Hydraulic dual circuit with Antilock Brake System (ABS)
Parking brake	Mechanical, internal expanding acting on transmission output shaft
Drum diameter	304.8 (12): MERITOR 12
mm(in.)	228.6 (9): BOSCH 9
Exhaust brake	Electric-pneumatic with valve in exhaust pipe

**CAB EQUIPMENT**

Cab construction	- All steel welded
Seating	- Three
	Driver's seat - Adjustable reclining, covered with fabric with air suspension
	Passenger's seat - Bench type, covered with fabric
Seat belts	- 3-point type (driver and passenger), one 2-point type (centre)
Heater/Defroster	- 18,357 BTU/h (4,627 Kcal/h)
Mirrors	outside rearview, chrome, 1 flat, heated and 1 convex on each side
Sun visors	- Two
Over-head console	- Two
Air conditioning	
Windshield	- Laminated
Windshield wipers	- Dual electric, 2-speed and intermittent
Cup holders	dash and console mounted
Electric power windows	
Electronic cruise control	
Cigarette lighter / 12V power outlet	
Power door lock	

**DASH INSTRUMENTATION**

Driver information display	
Meters and gauges, metric system	
Speedometer	- km/h (mph)
Odometer	(km/h)
Fuel gauge	
Coolant temperature gauge	
Engine tachometer	
Warning and pilot lamps and buzzers	
Oil pressure warning lamp and buzzer	
Brake pressure warning lamp and buzzer	
Coolant level warning lamp and buzzer	
Battery charging warning lamp	
High beam indicator lamp	
Turn signal pilot lamp	
Parking brake warning lamp	
Engine control system warning lamp	
ABS warning lamp	
Glow plug pre-heater indicator lamp	

**ELECTRICAL EQUIPMENT**

Batteries	Two, parallel connection, each 12 V
Capacity	1400 CCA
Alternator	12 V, 105 A brushless
Starter	12 V, 4.8 kW
Audio system	AM/FM radio with CD
Headlamps	2, composite type
Identification lamps (front)	
Stop/Tail lamps	
Back-up lamps	
Turn signals and hazard warning lamps	
Dome lamp	
Clearance lamps (front) LED type	
Electric horn (dual)	

**CHASSIS EQUIPMENT**

Fuel pre-filter	- Pre-filter (dust) and sedimenter (water) with heater - DAVCO
Reflectors	- Two rear, two front side
Hook	- One at front
Bumper	Chrome
Radiator Grille	Chrome

*See your authorized Hino Dealer for a complete list of options and accessories.*

**NOTE : All specifications of the products are with normal manufacturing allowances and tolerances. HINO MOTORS CANADA, LTD. reserves the right to alter specifications at any time without previous notice.**