

HINO 258LP SERIES



2011

TRUCK CHASSIS SPECIFICATIONS

(NE8J Lo-Pro) SS-NE028A
GVW: 11,570 kg (25,500 lbs.)

All 2011 models require ultra-low sulfur diesel fuel

DIMENSIONS (On standard specifications)

MODEL		NE8JMSA	NE8JPSA	NE8JRSA	NE8JTSA
Wheelbase	A mm(in.)	5,207 (205.0)	5,512 (217.0)	5,969 (235.0)	6,426 (253.0)
Overall length	B mm(in.)	8,143 (320.6)	9,007 (354.6)	9,464 (372.6)	9,921 (390.6)
Overall width	C mm(in.)	2,430 (95.7)	2,430 (95.7)	2,430 (95.7)	2,430 (95.7)
Overall height	D mm(in.)	2,610 (102.8)	2,610 (102.8)	2,610 (102.8)	2,610 (102.8)
Cab to axle	E mm(in.)	3,495 (137.6)	3,800 (149.6)	4,257 (167.6)	4,714 (185.6)
Rear overhang	F mm(in.)	1,905 (75.0)	2,464 (97.0)	2,464 (97.0)	2,464 (97.0)
Frame height at					
Front axle	G mm(in.)	830 (32.7)	830 (32.7)	830 (32.7)	830 (32.7)
Rear axle	H mm(in.)	910 (35.8)	910 (35.8)	910 (35.8)	910 (35.8)
Road clearance					
(at front axle)	J mm(in.)	180 (7.1)	180 (7.1)	180 (7.1)	180 (7.1)
Tread					
Front	K mm(in.)	2,020 (79.5)	2,020 (79.5)	2,020 (79.5)	2,020 (79.5)
Rear	L mm(in.)	1,840 (72.4)	1,840 (72.4)	1,840 (72.4)	1,840 (72.4)
Turning radius					
Tire	mm(in.)	8,430 (331.9)	8,880 (349.7)	9,550 (376.0)	10,220 (402.4)
Swept	mm(in.)	8,940 (352.0)	9,390 (369.7)	10,060 (396.1)	10,730 (422.4)

CHASSIS WEIGHTS (On std. spec., without spare tire & std. tool set)

MT Total weight	kg(lb.)	-	-	-	-	4,455 (9,820)
Front axle	kg(lb.)	-	-	-	-	2,870 (6,325)
Rear axle	kg(lb.)	-	-	-	-	1,585 (3,495)
AT Total weight	kg(lb.)	4,350 (9,590)	4,405 (9,710)	4,430 (9,770)	4,445 (9,800)	
Front axle	kg(lb.)	2,785 (6,140)	2,800 (6,170)	2,835 (6,255)	2,865 (6,315)	
Rear axle	kg(lb.)	1,565 (3,450)	1,605 (3,540)	1,595 (3,515)	1,580 (3,485)	

POWER LINE & PERFORMANCE

[11,570 kg (25,500 lbs.) GVW & 245/70R19.5 tires]

Power line	STD.	OPT.
Max. speed km/h	130	135
Gradeability (tan.θ) %	41.4	31.9
Transmission Model	Eaton FS5406A	Allison 2200 RDS
Type	Six-speed direct drive synchromesh 1st-6th	Six-speed automatic
1st.	9.008	3.102
2nd.	5.270	1.811
3rd.	3.220	1.406
Ratios	4th.	2.040
	5th.	1.361
	6th.	1.000
	Rev.	8.625
Rear axle gear ratios	3.070	4.110
Tire size	245/70R19.5	245/70R19.5

ENGINE

Model	HINO J08E-VC
Type:	Diesel 4-cy., 6-cyl. in-line, water-cooled
Combustion system:	Direct injection type
Max. output: (SAE Gross)	220HP at 2,500 rpm
Max. torque: (SAE Gross)	706 N·m (520 lb.-ft.) at 1,500 rpm
Bore and stroke:	112 x 130 mm (4.41 x 5.12 in.)
Piston displacement	7.684 L (468.8 cu.in.)
Fuel injection system:	Common rail ND
Governor:	Electronically controlled
Intake system:	Turbocharged and intercooled
Air cleaner:	Paper filter type ("DONALDSON")
Pre-heater:	Glow plug type
Fan clutch:	Bimetal thermostat sensor regulates fan speed
Block heater:	1,000 watts/120V immersion type

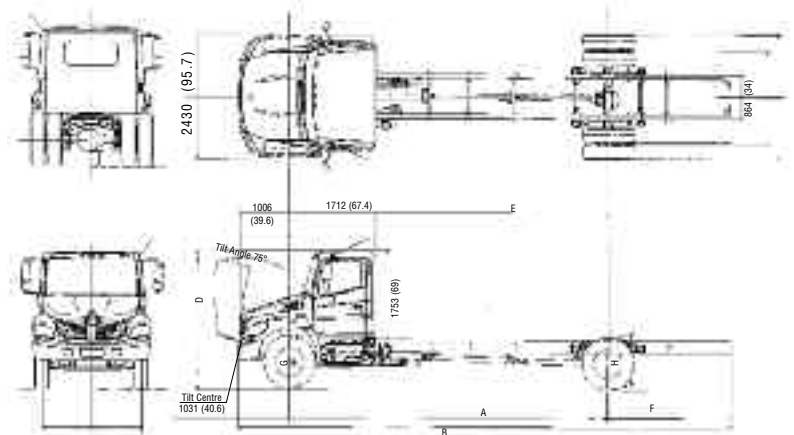

THE QUALITY CHOICE.

www.hinocanada.com

WEIGHT CAPACITIES

Front axle	kg (lbs.)	3,636 (8,000)
Rear axle	kg (lbs.)	7,955 (17,500)
Front spring	kg (lbs.)	3,636 (8,000)
Rear spring	kg (lbs.)	8,636 (19,000)

LIQUID CAPACITIES

Fuel tank ltr.(gal./US)	196.8 (52), aluminum
Cooling system	23.5 (6.21)
ltr.(gal./US)	: Eaton FS5406A
	23.0 (6.08)
	: ALLISON 2200 RDS
Diesel Exhaust Fluid, ltr. (gal.US)	19 (5.02)

AXLE / SUSPENSION

Front axle	MFS-8 series reversed Elliot, "I" beam, Oil lubricated front wheel bearings
Front spring	Taper-leaf springs w/ shock absorbers
Rear axle	RS17-145 series Full-floating, single reduction Single-speed hypoid gears, oil-lubricated type
Rear spring	Semi-elliptic main and auxiliary helper
Option:	Two air bag suspension with shock absorbers and dump valve

FRAME

Ladder type	Straight] section
Width mm(in.)	863.6 (34)
Tensile strength kg/mm ² (lb/in) ²	63.4 (90,143)
Resisting bending moment (one side) kg•cm (in•lbs.)	1,188,862 (1,031,900) no reinforcement

STEERING

Type	Telescopic and tilt steering column with lock Recirculating ball, with hydraulic booster integral type
------	--

CLUTCH

Type	Dry single plate self-adjusting EATON-SPICER Solo 1401 series
Facing material	Cerametallic
Facing outside diameter mm (in.)	350 (13.8)
Control	Hydraulic

WHEELS / TIRES

6 Wheels	19.5X6.75 8-stud disc.
6 Tires	245/70R19.5(G)
Brand & Pattern	BS Fr: RIB, Rr: LUG

BRAKES

Service brake	Hydraulic system with disc brakes for front and rear wheels, with automatic adjustment
Disc diameter	Front;
x pad area (cm ²)	390.5 x 122.3 x 18.8
x thickness	(15.375 x 18.96 x 0.74)
mm(in.)	Rear;
	390.5 x 122.3 x 18.8
	(15.375 x 18.96 x 0.74)
Control	Hydraulic dual circuit with Antilock Brake System (ABS)
Parking brake	Mechanical, internal expanding acting on the drive shaft
Drum diameter	304.8 (12)
mm(in.)	
Exhaust brake	Electric-pneumatic with valve in exhaust pipe

CAB EQUIPMENT

Cab construction	- All steel welded
Seating	- Three
Driver's seat	- Adjustable reclining, covered with fabric, with air suspension and armrest
Passenger's seat	- Bench type, covered with fabric
Seat belts	- 3-point type (driver and passenger), one 2-point type (centre)
Heater/Defroster	- 18,357 BTU/h (4,627 Kcal/h)
Power mirrors	- outside rearview, chrome, 1 flat, heated and 1 convex on each side
Sun visors	- Two
Over-head console	- Two
Air conditioning	
Windshield	- Laminated
Windshield wipers	- Dual electric, 2-speed and intermittent
Cup holders	
Electric power windows	
Electronic cruise control	
Cigarette lighter / 12V power outlet	
Power door locks	- keyless entry

DASH INSTRUMENTATION

Driver information display	
Meters and gauges, metric system	
Speedometer	- km/h (mph)
Odometer	(km/h)
Fuel gauge	
Diesel exhaust fluid gauge	
Coolant temperature gauge	
Engine tachometer	
Warning and pilot lamps and buzzers	
Oil pressure warning lamp and buzzer	
Coolant level warning lamp and buzzer	
Battery charging warning lamp	
High beam indicator lamp	
Turn signal pilot lamp	
Parking brake warning lamp	
Engine control system warning lamp	
ABS warning lamp	
Glow plug pre-heater indicator lamp	

ELECTRICAL EQUIPMENT

Batteries	Two, parallel connection, each 12 V
Capacity	1400 CCA
Alternator	12 V, 135 A brushless
Starter	12 V, 4.0 kW
Audio system	AM/FM radio with CD, DVD, GPS & Bluetooth®
Headlamps	2, composite type
Identification lamps (front)	LED type
Stop/Tail lamps	
Back-up lamps	
Turn signals and hazard warning lamps	
Dome lamps	
Front side marker lamps	
Clearance lamps (front)	LED type
Electrical horn (dual)	

CHASSIS EQUIPMENT

Fuel pre-filter	- Pre-filter (dust) and sedimenter (water) with heater, Davco
Reflectors	- Two rear, two front side
Hook	- One at front
Radiator Grille	- Chrome
Bumper	- Chrome

See your authorized Hino Dealer for a complete list of options and accessories.

NOTE : All specifications of the products are with normal manufacturing allowances and tolerances.

HINO MOTORS CANADA, LTD. reserves the right to alter specifications at any time without previous notice.