



2011

TRUCK CHASSIS SPECIFICATIONS

(NE8J) SS-NE024A
GVW: 11,818 kg (26,000 lbs.)

All 2011 models require ultra-low sulfur diesel fuel

DIMENSIONS (On standard specifications)

| MODEL | | NE8JMSA | NE8JPSA | NE8JRSA | NE8JTSA | NE8JVSA |
|-----------------|-----------|---------------|---------------|---------------|----------------|----------------|
| Wheelbase | A mm(in.) | 5,207 (205.0) | 5,512 (217.0) | 5,969 (235.0) | 6,426 (253.0) | 6,883 (271.0) |
| Overall length | B mm(in.) | 8,143 (320.6) | 9,007 (354.6) | 9,464 (372.6) | 9,921 (390.6) | 9,921 (390.6) |
| Overall width | C mm(in.) | 2,445 (96.3) | 2,445 (96.3) | 2,445 (96.3) | 2,445 (96.3) | 2,445 (96.3) |
| Overall height | D mm(in.) | 2,715 (106.9) | 2,715 (106.9) | 2,715 (106.9) | 2,715 (106.9) | 2,715 (106.9) |
| Cab to axle | E mm(in.) | 3,495 (137.6) | 3,800 (149.6) | 4,257 (167.6) | 4,714 (185.6) | 5,171 (203.6) |
| Rear overhang | F mm(in.) | 1,905 (75.0) | 2,464 (97.0) | 2,464 (97.0) | 2,464 (97.0) | 2,007 (79.0) |
| Frame height at | | | | | | |
| Front axle | G mm(in.) | 930 (36.6) | 930 (36.6) | 930 (36.6) | 930 (36.6) | 9430 (36.6) |
| Rear axle | H mm(in.) | 1,015 (40.0) | 1,015 (40.0) | 1,015 (40.0) | 1,015 (40.0) | 1,015 (40.0) |
| Road clearance | | | | | | |
| (at front axle) | J mm(in.) | 285 (11.2) | 285 (11.2) | 285 (11.2) | 285 (11.2) | 285 (11.2) |
| Tread | | | | | | |
| Front | K mm(in.) | 2,005 (78.9) | 2,005 (78.9) | 2,005 (78.9) | 2,005 (78.9) | 2,005 (78.9) |
| Rear | L mm(in.) | 1,830 (72.0) | 1,830 (72.0) | 1,830 (72.0) | 1,830 (72.0) | 1,830 (72.0) |
| Turning radius | | | | | | |
| Tire | mm(in.) | 8,340 (328.3) | 8,790 (346.1) | 9,450 (372.0) | 10,120 (398.4) | 10,780 (424.4) |
| Swept | mm(in.) | 8,870 (349.2) | 9,320 (366.9) | 9,980 (392.9) | 10,650 (419.3) | 11,310 (445.3) |

CHASSIS WEIGHTS (On std. spec., without spare tire & std. tool set)

| MT | Total weight | kg(lb.) | - | - | - | - | 4,665 (10,280) | 4,685(10,330) |
|----|--------------|---------|----------------|----------------|----------------|----------------|----------------|---------------|
| | Front axle | kg(lb.) | - | - | - | - | 2,975 (6,555) | 3,020 (6,660) |
| | Rear axle | kg(lb.) | - | - | - | - | 1,690 (3,725) | 1,665 (3,670) |
| AT | Total weight | kg(lb.) | 4,565 (10,060) | 4,615 (10,170) | 4,645 (10,240) | 4,660 (10,270) | 4,680(10,320) | |
| | Front axle | kg(lb.) | 2,890 (6,365) | 2,905 (6,400) | 2,945 (6,490) | 2,970 (6,545) | 3,015 (6,650) | |
| | Rear axle | kg(lb.) | 1,675 (3,695) | 1,710 (3,770) | 1,700 (3,750) | 1,690 (3,725) | 1,665 (3,670) | |

POWER LINE & PERFORMANCE

[11,818 kg (26,000 lbs.) GVW & 11.00R22.5-14 tires]

| Power line | □ STD. | □ OPT. |
|------------------------|---|------------------------|
| Max. speed km/h | 121 | 125 |
| Gradeability (tan.θ) % | 44.2 | 34.3 |
| Transmission Model | Eaton FS5406A | Allison 2200 RDS |
| Type | Six-speed direct drive synchromesh 1st-6th | Six-speed automatic |
| 1st. | 9.008 | 3.102 |
| 2nd. | 5.270 | 1.811 |
| 3rd. | 3.220 | 1.406 |
| 4th. | 2.040 | 1.000 |
| 5th. | 1.361 | 0.712 |
| 6th. | 1.000 | 0.610 |
| Rev. | 8.625 | 4.492 |
| Rear axle gear ratios | 4.110 | 5.570 |
| Tire size | 11R22.5-14 | 11R22.5-14 |

ENGINE

| Model | HINO J08E-VC |
|--------------------------|--|
| Type: | Diesel 4-cy., 6-cyl. in-line, water-cooled |
| Combustion system: | Direct injection type |
| Max. output: (SAE Gross) | 220HP at 2,500 rpm |
| Max. torque: (SAE Gross) | 706 N·m (520 lb.-ft.) at 1,500 rpm |
| Bore and stroke: | 112 x 130 mm (4.41 x 5.12 in.) |
| Piston displacement | 7.684 L (468.8 cu.in.) |
| Fuel injection system: | Common rail ND |
| Governor: | Electronically controlled |
| Intake system: | Turbocharged and intercooled |
| Air cleaner: | Paper filter type ("DONALDSON") |
| Fan clutch: | Bimetal thermostast sensor regulates fan speed |
| Block heater: | 1,000 watts/120V immersion type |

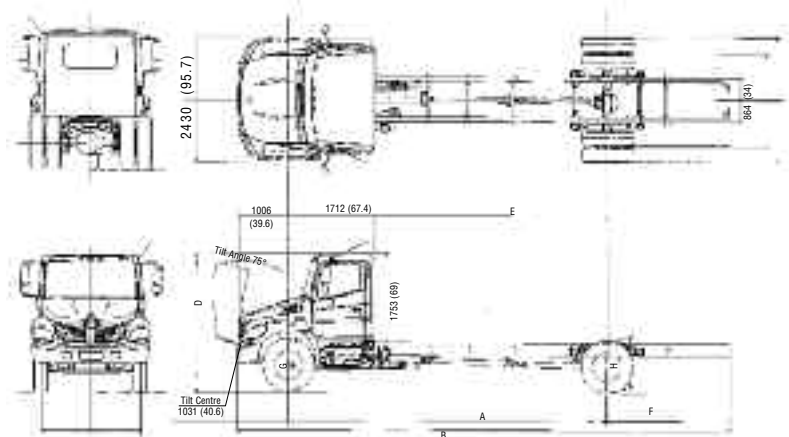

THE QUALITY CHOICE.

WEIGHT CAPACITIES

| | | |
|--------------|----------|----------------|
| Front axle | kg(lbs.) | 4,545 (10,000) |
| Rear axle | kg(lbs.) | 8,636 (19,000) |
| Front spring | kg(lbs.) | 5,455 (12,000) |
| Rear spring | kg(lbs.) | 8,636 (19,000) |

LIQUID CAPACITIES

| | |
|-------------------------------------|----------------------|
| Fuel tank ltr.(gal./US) | 196.8 (52), aluminum |
| Cooling system | 23.5 (6.21) |
| ltr.(gal./US) | : Eaton FS5406A |
| | 23.0 (6.08) |
| | : ALLISON 2200RDS |
| Diesel Exhaust Fluid, ltr. (gal.US) | 19 (5.02) |

AXLE / SUSPENSION

| | |
|--------------|--|
| Front axle | MFS-10 series reversed Elliot, "I" beam, Oil lubricated front wheel bearings |
| Front spring | Taper-leaf springs w/ shock absorbers |
| Rear axle | RS19-145 series Full-floating, single reduction Single-speed hypoid gears, oil lubricated type |
| Rear spring | Semi-elliptic main and auxiliary helper, -leaf spring |
| Option: | Two air bag suspension with shock absorbers and dump valve |

FRAME

| | |
|---|--|
| Ladder type | Straight] section |
| Width mm(in.) | 863.6 (34) |
| Tensile strength | 63.4 (90,143) |
| kg/mm ² (lb/in) ² | |
| Resisting bending moment (one side) | 1,188,862 (1,031,900) no reinforcement |
| kg•cm (in•lbs.) | |

STEERING

| | |
|------|--|
| Type | Telescopic and tilt steering column with lock |
| | Recirculating ball, with hydraulic booster integral type |

CLUTCH

| | |
|----------------------------------|---|
| Type | Dry single plate self-adjusting EATON-SPICER Solo 1401 series |
| Facing material | Cerametallic |
| Facing outside diameter mm (in.) | 350 (13.8) |
| Control | Hydraulic |

WHEELS / TIRES

| | |
|-----------------|--------------------------|
| 6 Wheels | 22.5X8.25, 10-stud disc. |
| 6 Tires | 11R22.5(G) |
| Brand & Pattern | BS Fr: RIB, Rr: LUG |

BRAKES

| | |
|-------------------------------|--|
| Service brake | Hydraulic system with disc brakes for front and rear wheels, with automatic adjustment |
| Disc diameter | Front; |
| x pad area (cm ²) | 390.5 x 122.3 x 18.8 |
| x thickness | (15.375 x 18.96 x 0.74) |
| mm(in.) | Rear; |
| | 390.5 x 122.3 x 18.8 |
| | (15.375 x 18.96 x 0.74) |
| Control | Hydraulic dual circuit with Antilock Brake System (ABS) |
| Parking brake | Mechanical, internal expanding acting on the drive shaft |
| Drum diameter | 304.8 (12) |
| mm(in.) | |
| Exhaust brake | Electric-pneumatic with valve in exhaust pipe |

CAB EQUIPMENT

| | |
|---------------------------|--|
| Cab construction | - All steel welded |
| Seating | - Three |
| Driver's seat | - Adjustable reclining, covered with fabric, with air suspension and armrest |
| Passenger's seat | - Bench type, covered with fabric |
| Seat belts | - 3-point type (driver and passenger), one 2-point type (centre) |
| Heater/Defroster | - 18,357 BTU/h (4,627 Kcal/h) |
| Power mirrors | - outside rearview, chrome, 1 flat, heated and 1 convex on each side |
| Sun visors | - Two |
| Over-head console | - Two |
| Air conditioning | |
| Windshield | - Laminated |
| Windshield wipers | - Dual electric, 2-speed and intermittent |
| Cup holders | |
| Electric power windows | |
| Electronic cruise control | |
| Cigarette lighter | / 12V power outlet |
| Power door locks | , keyless entry |

DASH INSTRUMENTATION

| | |
|--|--------------|
| Driver information display | |
| Meters and gauges, metric system | |
| Speedometer | - km/h (mph) |
| Odometer | (km/h) |
| Fuel gauge | |
| Diesel exhaust fluid gauge | |
| Coolant temperature gauge | |
| Engine tachometer | |
| Warning and pilot lamps and buzzers | |
| Oil pressure warning lamp and buzzer | |
| Brake pressure warning lamp and buzzer | |
| Coolant level warning lamp and buzzer | |
| Battery charging warning lamp | |
| High beam indicator lamp | |
| Turn signal pilot lamp | |
| Parking brake warning lamp | |
| Engine control system warning lamp | |
| ABS warning lamp | |

ELECTRICAL EQUIPMENT

| | |
|---------------------------------------|--|
| Batteries | Two, parallel connection, each 12 V |
| Capacity | 1400 CCA |
| Alternator | 12 V, 135 A brushless |
| Starter | 12 V, 4.8 kW |
| Audio system | AM/FM radio with CD, DVD, GPS & Bluetooth® |
| Headlamps | 2, composite type |
| Identification lamps (front) | |
| Stop/Tail lamps | |
| Back-up lamps | |
| Turn signals and hazard warning lamps | |
| Dome lamps | |
| Front side marker lamps | |
| Clearance lamps (front) LED type | |
| Electrical horn (dual) | |

CHASSIS EQUIPMENT

| | |
|-----------------|--|
| Fuel pre-filter | - Pre-filter (dust) and sedimenter (water) with heater - DAVCO |
| Reflectors | - Two rear, two front side |
| Hook | - One at front |
| Bumper | Chrome |
| Radiator Grille | Chrome |

See your authorized Hino Dealer for a complete list of options and accessories.

NOTE : All specifications of the products are with normal manufacturing allowances and tolerances. HINO MOTORS CANADA, LTD. reserves the right to alter specifications at any time without previous notice.