

HINO 155 SERIES**2012****TRUCK CHASSIS SPECIFICATIONS****Spec. No. SS-XJ302A**
GVW: 6,580 kg (14,500 lbs.)

All 2012 models require ultra-low sulfur diesel fuel

DIMENSIONS (On standard specifications)

MODEL		155-1	155-2	155-3
Wheelbase	mm (in)	2,900 (114.2)	3,500 (137.8)	3,800 (149.6)
Overall length	mm (in)	5,206 (205.0)	5,806 (228.6)	6,105 (240.4)
Overall width	mm (in)	2,130 (83.9)	2,130 (83.9)	2,130 (83.9)
Overall height	mm (in)	2,354 (92.7)	2,350 (92.5)	2,350 (92.5)
Cab width	mm (in)	1,995 (78.5)	1,995 (78.5)	1,995 (78.5)
Frame width	mm (in)	838 (33.0)	838 (33.0)	838 (33.0)
Cab to axle	mm (in)	2,342 (92.2)	2,942 (115.8)	3,242 (127.6)
Front overhang	mm (in)	1,126.5 (44.4)	1,126.5 (44.4)	1,126.5 (44.4)
Front overhang frame	mm (in)	1,033 (40.7)	1,033 (40.7)	1,033 (40.7)
Rear overhang	mm (in)	1,175 (46.3)	1,175 (46.3)	1,175 (46.3)
Frame height at Front axle	mm (in)	721 (28.4)	716 (28.2)	715 (28.1)
Rear axle	mm (in)	808 (31.8)	811 (31.9)	812 (32.0)
Road clearance (at diff. case)	mm (in)	179 (7.0)	179 (7.0)	179 (7.0)
Tread Front	mm (in)	1,655 (65.2)	1,655 (65.2)	1,655 (65.2)
Rear	mm (in)	1,660 (65.4)	1,660 (65.4)	1,660 (65.4)
Turning radius Tire	mm (in)	4,960 (195.3)	5,840 (229.9)	6,290 (247.6)
Turning radius Swept	mm (in)	5,650 (222.4)	6,540 (257.5)	6,980 (274.8)

CHASSIS WEIGHTS (On std. spec., without spare tire & std. tool set)

		155-1	155-2	155-3
Total weight	kg(lb.)	2,883 (6,356)	2,924 (6,447)	2,931 (6,462)
Front axle	kg(lb.)	1,845 (4,068)	1,968 (4,339)	1,987 (4,381)
Rear axle	kg(lb.)	1,038 (2,288)	956 (2,108)	944 (2,081)

ENGINE

Model	HINO J05E-TP
Type:	Diesel, 4-cylinder in-line, water-cooled
Combustion system:	Direct injection type
Max. output: (SAE Gross)	210HP at 2,500 rpm
Max. torque: (SAE Gross)	597 N•m (440 lb.-ft.) at 1,500 rpm
Bore and stroke:	112 x 130 mm (4.41 x 5.12 in.)
Piston displacement	5.123 L (312.6 cu.in.)
Fuel injection system:	Radial plunger pump (HP-3)
Governor:	Electronically controlled
Intake system:	Turbocharged and intercooled
Air cleaner:	Paper filter type ("DONALDSON")
Fan clutch:	Bimetal thermostat sensor regulates fan speed
Exhaust gas after treatment system	DEF - SCR Dosing system
Glow plugs	Standard
Engine block heater	1,000 watts/120V immersion type

POWER LINE & PERFORMANCE [6,580 kg (14,500 lbs.) GVW & 215-85R16 tires]

Power line	
Max. speed km/h	125
Gradeability (tan.θ) %	84.4
Transmission Model	A465
Type	Six-speed automatic
1st.	3.742
2nd.	2.003
3rd.	1.343
Ratios 4th.	1.000
5th.	0.773
6th.	0.634
Rev.	3.539
Rear axle gear ratios	4.625

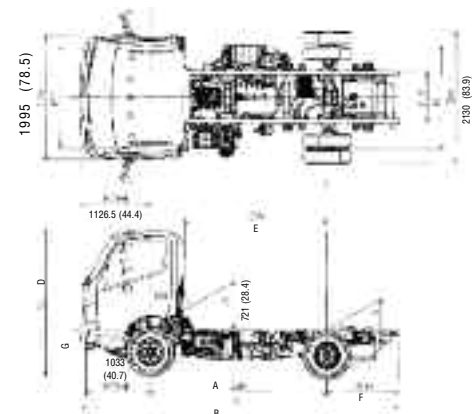
**THE QUALITY CHOICE.**

www.hinocanada.com

WEIGHT CAPACITIES

Front axle	kg(lbs.)	2,430 (5,360)
Rear axle	kg(lbs.)	4,480 (9,880)

LIQUID CAPACITIES

Fuel tank	114 (30) for 114.2" WB
ltr.(gal./US)	125 (33) for 137.8" and 149.6" WB
Cooling system	21.0L (5.54 gal./US)
Diesel Exhaust Fluid, ltr. (gal.US)	19 (5.02)

AXLE / SUSPENSION

Front axle	Reversed Elliot, "I" beam
Front spring	Taper leaf springs with shock absorbers and stabilizer bar
Rear axle	Full-floating, single reduction Single-speed by hypoid gears
Rear spring	Taper-leaf springs with shock absorbers

FRAME

Ladder type	Straight section
Max. section (depth x flange x thickness) mm(in.)	210 x 70 x 5.0 (8.27 x 2.8 x 0.20)
Yield point of material kg/mm ² (PSI)	40.0(56,900)
Resisting bending moment kgf•mm (in•lbs.)	8,144,000 (706,900)
Front bumper	Resin material

STEERING

Type	Tilt and telescopic steering column with lock Recirculating ball, with hydraulic booster integral type
------	--

WHEELS / TIRES

6 Wheels	16X6K-127 6-stud disc.
6 Tires	215/85R16
Brand & Pattern	Bridgestone Fr-RIB Rr-LUG type

BRAKES

Service brakes	Hydraulic system with disc brakes for front and rear wheels, with ABS
Control	Vacuum assist, dual circuit
Disc diameter(mm)	Front;
x pad area(cm ²)	287 x 84 x 13
x thickness(mm)	(11.3 x 3.31 x 0.51)
(in)	Rear;
	287 x 84 x 13 (11.3 x 3.31 x 0.51)
Parking brake	Mechanical, internal expanding acting on transmission output shaft
Drum diameter mm(in)	203 (8)
Exhaust brake	Electric-pneumatic with valve in exhaust pipe

CAB EQUIPMENT

Cab construction	- All steel, welded
Seating	- Three
Driver's seat	- 2-way adjustable high-back seat, fabric covered, magnetic suspension
Passenger's seat	- Fixed high-back seat, fabric covered
Center passenger's seat	- Foldaway type with seat back console, fabric covered
Seat belts	- 3-point type for driver and passenger, 2-point type for center passenger
Heater/Defroster	- 18,596 BTU/h (4,687 Kcal/h)
Air conditioning	
Outside rearview mirrors	- 2, heated, remote control
Coat hook	
Sun visors	- 2
Over-head console	- 2
Windshield	- Laminated
Windshield wipers	- Dual electric, 2-speed and intermittent
Cup Holders	2, dash mounted
Electric power windows	
Cigarette lighter	
Electric door locks, keyless entry	
Door pockets	
Vinyl floor carpet	
Cruise control	

CHASSIS EQUIPMENT

Fuel pre-filter and sedimenter, with heater
Towing hook
Reflectors, 2
Chrome grille

DASH INSTRUMENTATION

Meters and gauges, metric system
Speedometer - km/h (mph)
Odometer - km
Fuel gauge
Coolant temperature gauge
Engine tachometer
Economy meter
Warning lamps and buzzers
Oil pressure warning lamp and buzzer
Brake fluid level warning lamp
Battery charging warning lamp
High beam indicator lamp
Turn signal pilot lamp
Parking brake warning lamp
Engine control system warning lamp
ABS warning lamp
Cab tilt warning lamp and buzzer
Exhaust brake indicator lamp
Transmission oil temperature warning lamp
Fuel level warning lamp
Back-up warning buzzer
Hazard indicator lamp
Air cleaner warning lamp

ELECTRICAL EQUIPMENT

Batteries	2, 12V GR27, parallel connection
Capacity	1244 CCA
Alternator	12 V, 130 A
Starter	12 V, 3.35 kW
Audio system	AM/FM radio with CD, DVD, GPS & Bluetooth®
Headlamps, 2, composite type	
Stop/Tail lamps	
Identification lamps	
Back-up lamps	
License plate lamp	
Directional indicator and hazard lamp	
Dome lamp	
Clearance lamps	
Parking lamps	
Day time running lights	
Fender marker lamps	
Electrical Horn	

See your authorized Hino Dealer for a complete list of options and accessories.

NOTE : All specifications of the products are with normal manufacturing allowances and tolerances.

HINO MOTORS CANADA, LTD. reserves the right to alter specifications at any time without previous notice.